

DETAILS OF FIXING

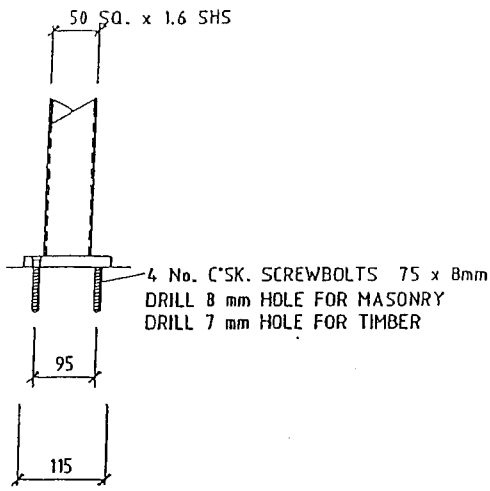

Handrail Post Base

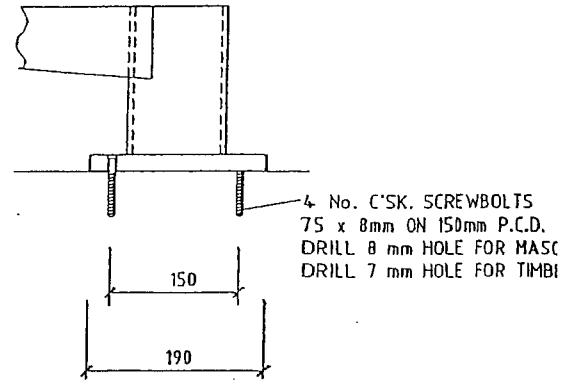

Base Plate

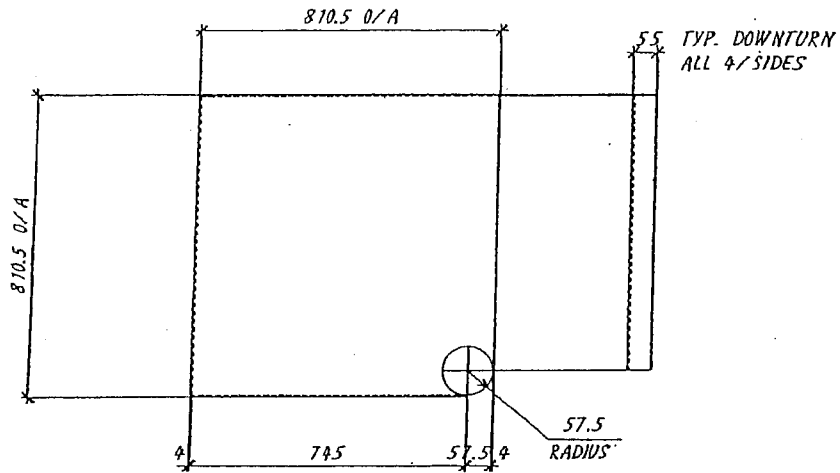

LANDING DETAIL

EXAMPLES OF SETOUT

1500 Diameter

205mm to 220mm Riser

14 Treads to circle at 25.7°

Floor to Floor Height	2630	2850	3070	3290	3510	3730	3950	4170	4390	4610	4830
Number of Risers	12	13	14	15	16	17	18	19	20	21	22
Number of Treads	11	12	13	14	15	16	17	18	19	20	21
Going	282	308	334	360	385	411	437	463	488	514	540
14 Steps to circle at 25.7°											

SOME TYPICAL TOP LANDING EXAMPLES

DOTTED LINE DENOTES FIXING FACE

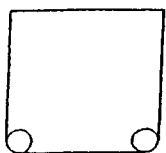

CORNER SQUARE

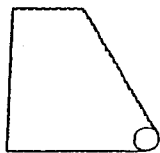

CORNER TRIANGLE

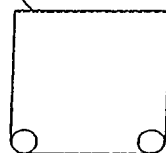

CANTILEVER

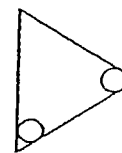

BALCONY TRIANGLE

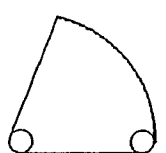

ROUND TRIANGLE